



*Innovative Combustion Solutions Worldwide*

# Locktite Manual Reset Gas Shut-Off Valves

*Series 200 LT*

- UL listed, FM & CSA approved.
- Snap-acting solenoid for fast closing.
- Two visual indicators of valve position.
- Raintight construction.
- Soft seat disc for positive shut-off.
- Two built-in auxilliary switches.
- Ball bearing trip mechanism reduces wear.
- Lever with extension chains available for remote mounting.
- 100% factory tested before shipment.

U.S. Patent No. 3,259,357  
Canadian Patent No. 764,833



LISTED 326R



CGA 3.9  
CSA 6.5 / ANSI Z21.21

Eclipse 200 LT valves are manually opening valves that automatically shut off the gas supply to a combustion system when any interlocking limit switch opens. The valve handle cannot be reset until the condition causing the open switch is corrected and all limit switches are closed. Typical limit switches include air pressure, gas pressure, temperature limit, and flame monitoring contacts. In the event of a power failure, the valve immediately closes.

Series 200 LT valves include two visual indicators of "open" or "closed" position: a red "flag" visible in the plastic dome on top of the valve; and the reset handle position as indicated by cast markings on the operator case. These valves also include two SPDT micro-switches that can be used for auxiliary circuits. Two contacts are made when the valve opens, and two are made when the valve is closed.



## 200 LT Specifications

<b>Temperature Limits</b>	+125° to -20° F (+52° to -29° C) fluid and ambient . Below 32° F (0° C) the gas must be free of water vapor which could condense and freeze within the valve.	
<b>Maximum Inlet &amp; Differential Pressure</b>	1" thru 2" 2-1/2" thru 4"	30 psig 20 psig
<b>Gases</b>	UL listed for air, natural gas, LP gas and hydrogen. FM approved for natural, LP and manufactured gases. CSA approved for natural, LP, mixed and manufactured gases.  Contact Eclipse for other gases. For corrosive or wet gases such as coke oven or digester gas, corrosion-resistant valve trim must be installed at Eclipse.	
<b>Electrical</b>	Volts/Cycles	115/120 volt 50/60 hz standard. 220/50 or 240/60 available.
	Holding Current	35 VA at 120 volt
	Auxiliary Switches (2)	8 amp, 1/3 hp, 120 or 240 volts A.C.
<b>Approvals</b>	UL listed, FM & CSA approved.	

### Design Features

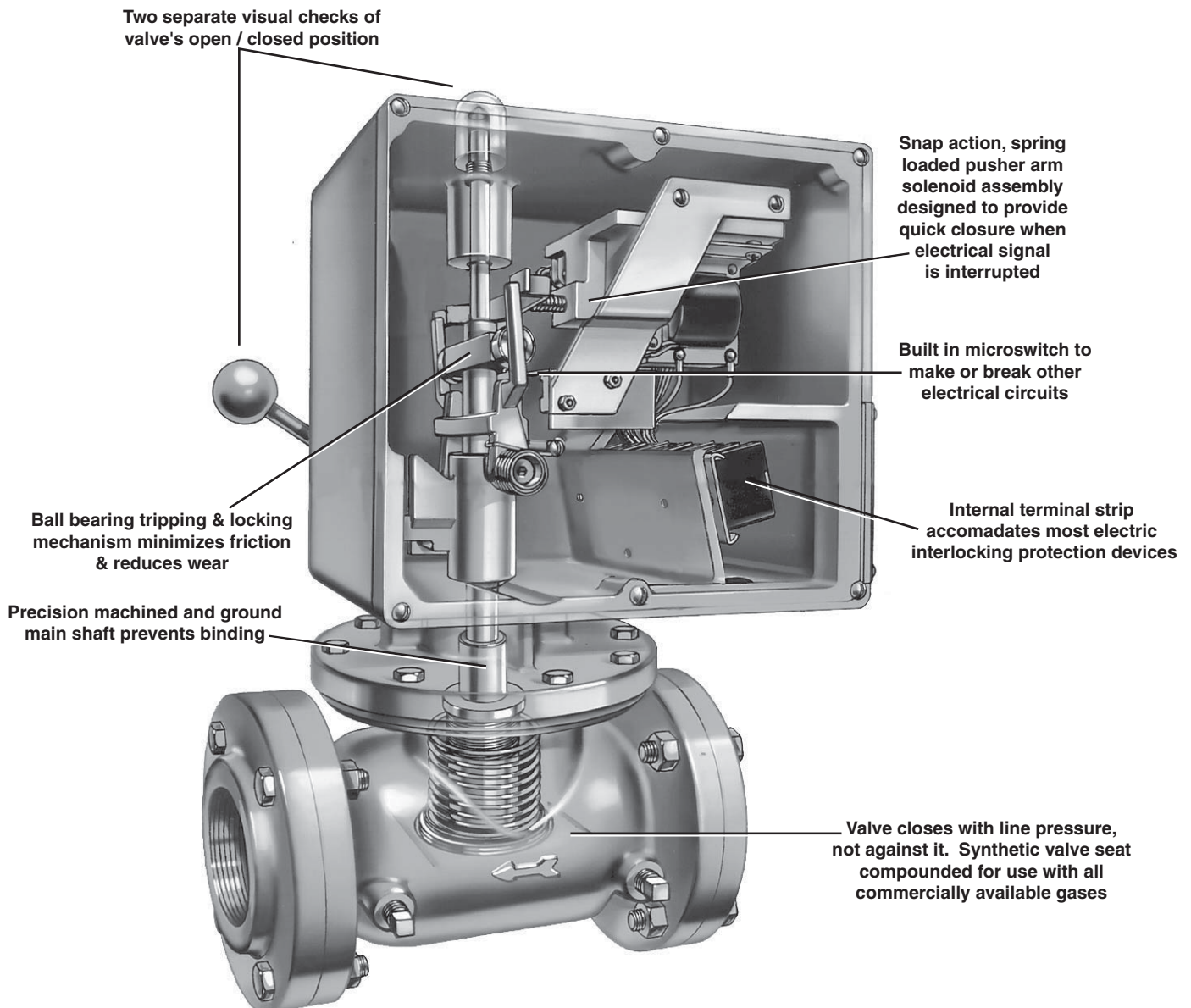

### Capacities\*

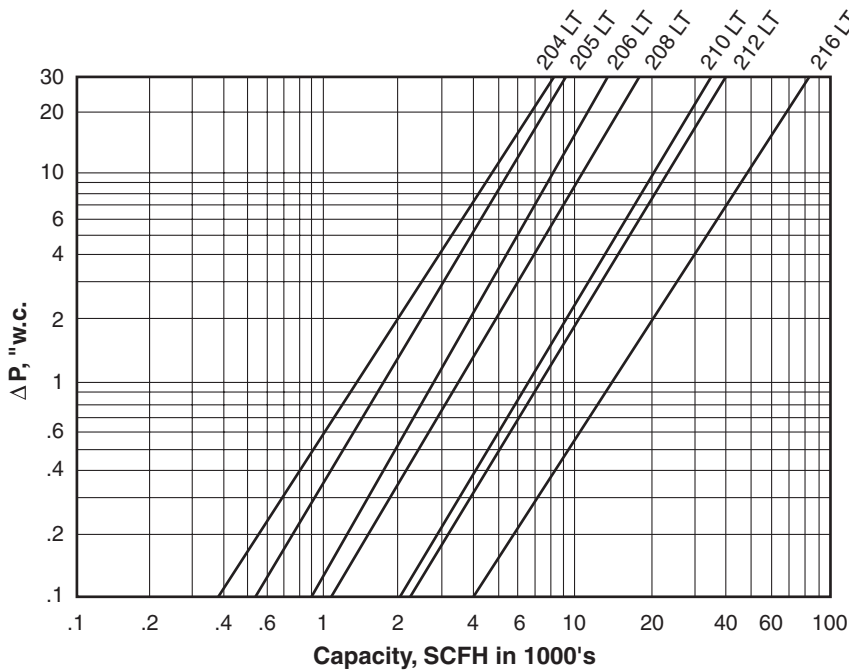

\*For natural gas (.6 s.g.) with an inlet pressure no higher than 1.1 psig. For other gases, multiply capacity by:

Butane (2.0 s.g.)	.548
Propane (1.5 s.g.)	.628
Air (1.0 s.g.)	.775

### Allowable Mounting Positions

Factory Supplied Operator Position	#1 (Standard)	#2	#3	#4
Part Number Designation	Assembly No. (None)	Assembly No. -P2	Assembly No. -P3	Assembly No. -P4
Valve Mounted With Operator Straight Up or Down				
Valve Mounted With Wiring Box Cover Facing Up				

200 LT valves can be supplied with the operator rotated in any of four positions with respect to the valve body, #1, #2, #3, and #4. Position #1 is supplied standard. Add -P2, -P3, or -P4 to the end of the assembly number to specify other mounting positions. The sketches above show the allowable mounting orientations for each of the four factory-supplied operator positions. The operator must not be mounted in a position other than those shown.



*Note:* Field changing the operator position can result in damage. Please contact your Eclipse representative if rotation of the operator after shipment is required.

## 200 LT Dimensions

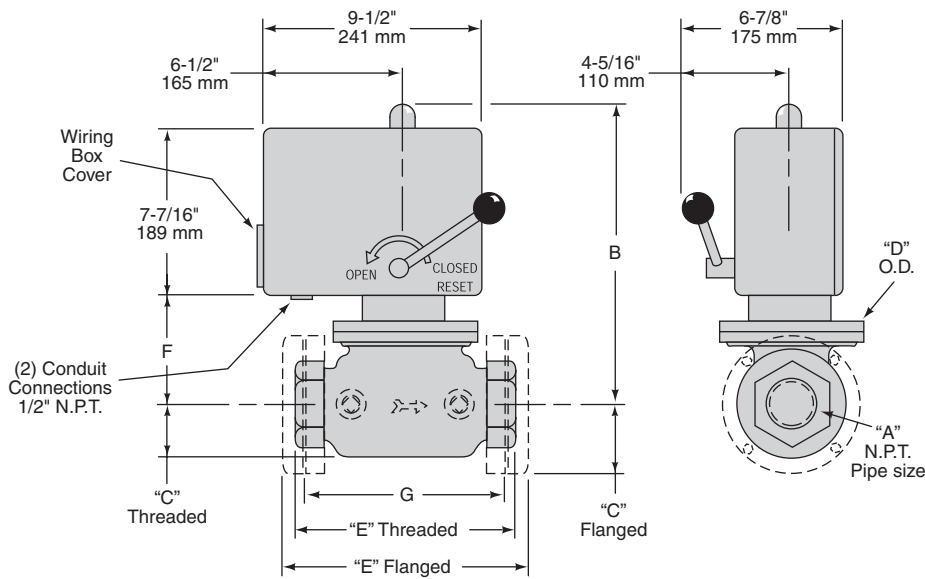

*Note: Valve mounting position (see page 3) must be specified at the time of order. The part number is the combination of the assembly number and the position designator.*

**Assembly No.**   **Position**

Position is:

- BLANK for Position #1
- P2 for Position #2
- P3 for Position #3
- P4 for Position #4

**Example:** To order 1-1/2" threaded iron body for 240 VAC in position 2 use **571606-1-P2**

### English Units

Catalog Number	Assembly Number		C <sub>v</sub> Open	Dimensions In Inches							Net Lbs.
	120 V.	240 V.		A	B	C	D	E	F	G	
<b>Threaded Iron Body</b>											
204 LT-IS	571604	571604-1	23.4	1	12-1/16	1-1/2	5-1/2	7-1/4	3-11/16	---	26
205 LT-IS	571605	571605-1	29.8	1-1/4	12-1/16	1-1/2	5-1/2	7-1/4	3-11/16	---	26
206 LT-IS	571606	571606-1	50.4	1-1/2	12-5/8	2-1/16	5-1/2	9	4-5/16	---	32
208 LT-IS	571608	571608-1	58.5	2	12-5/8	2-1/16	5-1/2	9	4-5/16	---	30
<b>Flanged Aluminum Body</b>											
204 LT-AF	560604	560604-1	23.4	1	12-3/16	1-3/4	5-7/8	7-1/16	3-13/16	5-7/8	23
205 LT-AF	560605	560605-1	29.8	1-1/4	12-3/16	1-3/4	5-7/8	7-1/16	3-13/16	5-7/8	23
206 LT-AF	560606	560606-1	50.4	1-1/2	12-3/4	2-1/2	5-7/8	9	4-13/16	7	28
208 LT-AF	560608	560608-1	58.5	2	12-3/4	2-1/2	5-7/8	9	4-13/16	7	27
216 LT-AF	560616	560616-1	234.0	4	16-3/16	4	7-15/16	15-5/8	7-13/16	13	60
<b>Flanged Iron Body</b>											
210 LT-IF	560611	560611-1	116.0	2-1/2	14-1/8	3-1/16	7-7/8	12-5/8	5-3/4	9-3/4	52
212 LT-IF	560613	560613-1	126.0	3	14-1/8	3-1/16	7-7/8	12-1/4	5-3/4	9-3/4	52

### Metric Units

Catalog Number	Assembly Number		C <sub>v</sub> Open	Dimensions In Millimeters							Net Kgs.
	120 V.	240 V.		A	B	C	D	E	F	G	
<b>Threaded Iron Body</b>											
204 LT-IS	571604	571604-1	23.4	1"	306	38	140	184	94	---	11.8
205 LT-IS	571605	571605-1	29.8	1-1/4"	306	38	140	184	94	---	11.8
206 LT-IS	571606	571606-1	50.4	1-1/2"	321	52	140	229	110	---	14.5
208 LT-IS	571608	571608-1	58.5	2"	321	52	140	229	110	---	13.6
<b>Flanged Aluminum Body</b>											
204 LT-AF	560604	560604-1	23.4	1"	310	44	149	195	97	149	10.4
205 LT-AF	560605	560605-1	29.8	1-1/4"	310	44	149	195	97	149	10.4
206 LT-AF	560606	560606-1	50.4	1-1/2"	324	64	149	229	122	178	12.7
208 LT-AF	560608	560608-1	58.5	2"	324	64	149	229	122	178	12.2
216 LT-AF	560616	560616-1	234.0	4"	411	102	202	397	198	330	27.2
<b>Flanged Iron Body</b>											
210 LT-IF	560611	560611-1	116.0	2-1/2"	359	78	200	321	146	248	23.5
212 LT-IF	560613	560613-1	126.0	3"	359	78	200	321	146	248	23.5



**Eclipse Combustion**



**Offered By:**

Power Equipment Company  
2011 Williamsburg Road  
Richmond, Virginia 23231  
Phone (804) 236-3800  
Fax (804) 236-3882

---

[www.peconet.com](http://www.peconet.com)